

SERIE EOS

3.1.7.0.

Pompa a Pistoni Piston Pump

CODICE DI ORDINAZIONE - DECODING

3.1.7.0 . XXX . X . X . 00

ROTAZIONE/ROTATION

1 = SINISTRO/ANTICLOCKWISE
2 = DESTRO/CLOCKWISE

1 = UNI 3 FORI/3 HOLES UNI
2 = DIN 4 FORI/4 HOLES DIN

CILINDRATA/DISPLACEMENT

CODICE BASE/BASIC CODE

TIPO - TYPE	CODICE - CODE
EOS 12	3.1.7.0.012.X.X.00
EOS 16	3.1.7.0.016.X.X.00
EOS 25	3.1.7.0.025.X.X.00

UNI
21-222

EOS 12
EOS 16
EOS 25

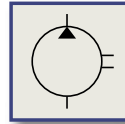

DIN
5 4 6 2
SE

EOS 12
EOS 16
EOS 25

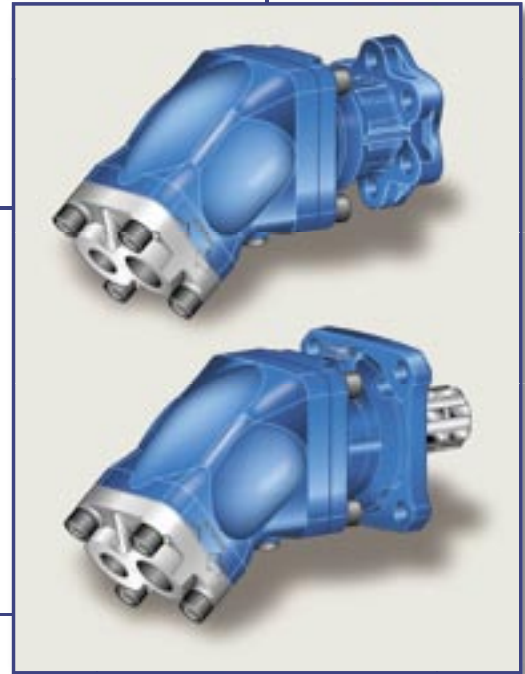
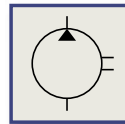

CARATTERISTICHE E DATI TECNICI - SPECIFICATIONS AND TECHNICAL DATA

TIPO - TYPE			EOS 12	EOS 16	EOS 25
Cilindrata Displacement	Vg	cm ³ /n cm ³ /rev.	12.01	16.81	25.61
Pressione massima Max operating pressure	P1	bar	450	450	450
Pressione massima di picco Max peak pressure (≤ 0.1 s)	P3		500	500	500
Velocità massima intermittente Max intermittent speed (P ≤ 30 bar)	n3	n/min r.p.m.	3100	3100	3000
Velocità massima continua Max continuous speed (≤ P1)	n1		2800	2800	2600
Velocità minima intermittente Min intermittent speed (≤ P2 x 0.5) (max 30 s)	n4		300		
Pressione in aspirazione (assoluta) Suction pressure (absolute)	P	bar	0.7 ÷ 1.5		
Campo di viscosità lavoro Operating viscosity range	√	cST	9 ÷ 75		
Campo di viscosità ottimale Optimal viscosity range	√		15 ÷ 46		
Massima viscosità avviamento Start up max viscosity	√		1000		
Temperatura fluido °C (t) Fluid temperature °C (t)	t	°C	-25° ÷ 80°		

DIMENSIONI - DIMENSIONS

**UNI
21-222**

**3 FORI
3 HOLES**

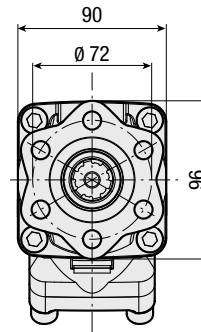
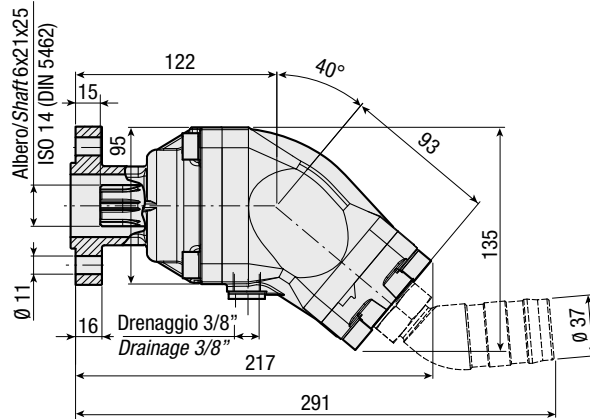
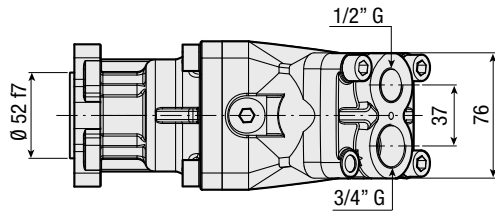

DIMENSIONI - DIMENSIONS

**DIN
5462**

**4 FORI
4 HOLES**

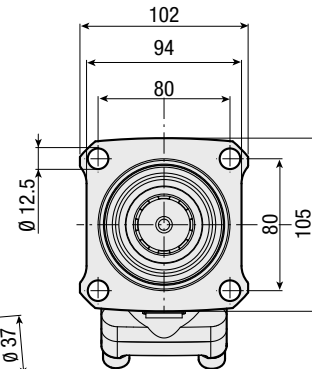
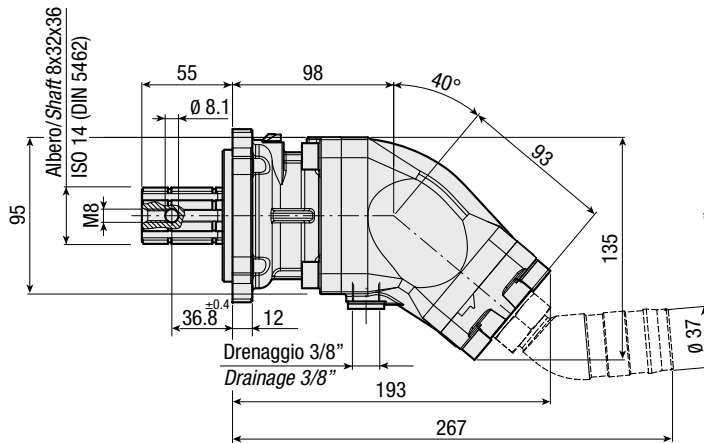
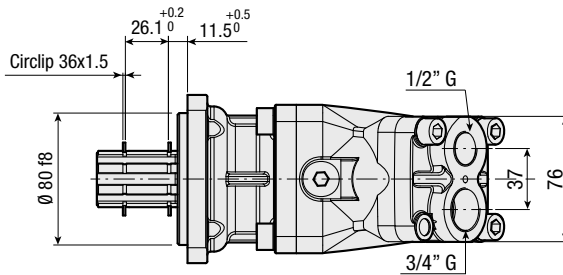

SERIE EOS 3.1.70.

POMPE A PISTONI PISTON PUMPS

2



SERIE EOS 3.1.7.0.

EOS 12
EOS 16
EOS 25

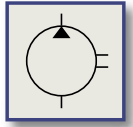

DIAGRAMMI - DIAGRAMS

PORTATA - CAPACITY

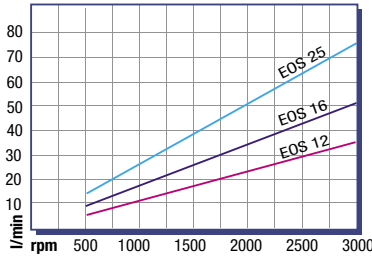

POTENZA ASSORBITA - ABSORBED POWER

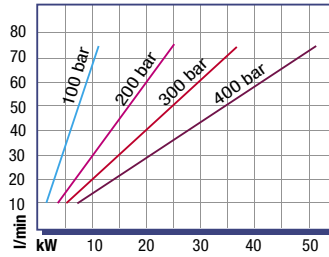

COPPIA ASSORBITA - INPUT TORQUE

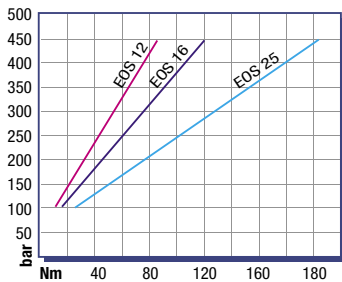

RILIEVI ESEGUITI CON OLIO
ISO VG 46 A 50° C ($\nu=30$ cSt)
THE ABOVE SPECIFICATIONS
REFER TO OIL TYPE ISO
VG 46 AT 50° C ($\nu=30$ cSt)

FILTRAZIONE - FILTERING

> Si raccomanda filtrazione sul ritorno (o mandata) come da tabella a lato.

La filtrazione in aspirazione è sconsigliata in quanto può generare fenomeni di cavitazione. Qualora si rendesse indispensabile, rispettare i valori limite di depressione previsti di -0,3 bar (corrispondente a 0,7 bar assoluti).

> *Filtering on return line (or outlet) recommended. Refer to the side table.*

A filter on the inlet is not recommended because of possible cavitation problems. If it is necessary, the suction pressure limit of -0,3 bar (corresponding to 0,7 absolute bar) must be respected.

Pressione Lavoro Working Press. P2	Contaminazione - Contamination		Filtro - Filter $\beta_x = 75$
	NAS 1638	ISO 4406	
≤ 200 bar	10	19/16	25 μm
< 300 bar	9	18/15	20 μm
≥ 300 bar	8	17/14	10 μm

RACCORDERIA - FITTINGS

> Avvitare sulla pompa raccordi GAS-CILINDRICO (BSP) a tenuta frontale. **NON** applicare raccordi con filettatura conica.

> *Make use of cylindric gas-fittings (BSP) with O-ring, bonded-seal on the pump. Do **NOT** use fittings with conical thread.*

NORME PER L'INSTALLAZIONE - INSTALLATION INSTRUCTIONS

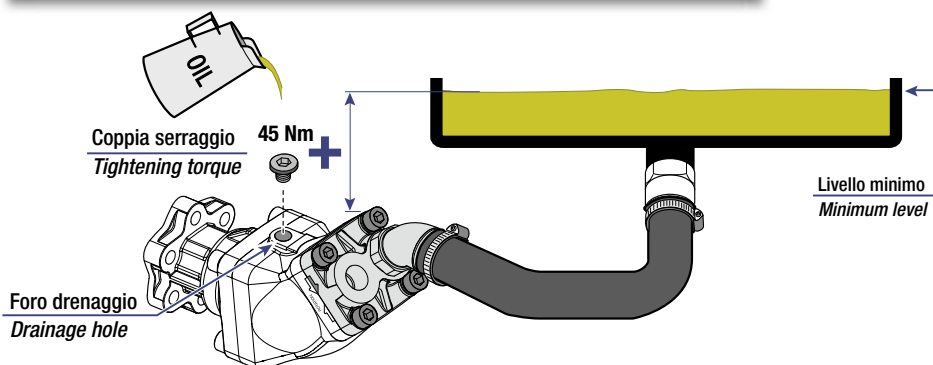

PRIMA DELL'AVVIAMENTO ASSICURARSI CHE LA POMPA SIA RIEMPITA D'OLIO O SPURGANDO L'ARIA DAL TAPPO DI DRENAGGIO O RIEMPIENDOLA PREVENTIVAMENTE.

BEFORE STARTING UP MAKE SURE THAT THE PUMP IS FILLED WITH OIL, EITHER BY BLEEDING THE AIR THROUGH THE DRAINAGE HOLE OR BY FILLING THE PUMP PREVIOUSLY.

Il mancato rispetto della norma può provocare danneggiamenti alla pompa.
Failing to observe this rule may cause damages to the pump.

SENSO DI ROTAZIONE/CAMBIO ROTAZIONE - DIRECTION OF ROTATION/CHANGE OF ROTATION

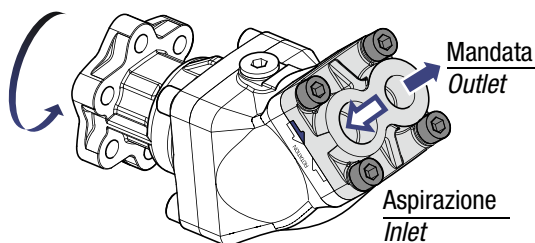

Determinazione senso di rotazione.

Choosing the direction of rotation.

POMPA ROTAZIONE DESTRA
(P.T.O. ROTAZIONE SINISTRA)

CLOCKWISE ROTATING PUMP
(ANTICLOCKWISE ROTATING P.T.O.)

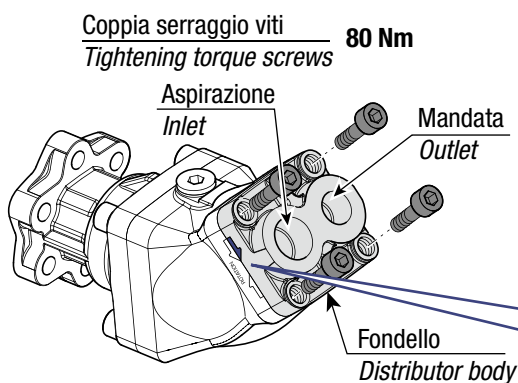

Per invertire il senso di rotazione, togliere le 4 viti e, tenendo accostato il fondello, ruotarlo di 180°. Serrare le 4 viti a 80 ± 5 Nm.

To change the direction of rotation remove the 4 screws and, keeping the distributor body close to the pump, rotate it by 180°. Tighten the 4 screws at 80 ± 5 Nm.

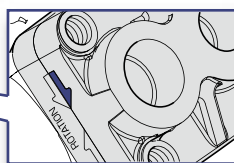

FRECCIA + TACCA = SENSO DI ROTAZIONE

ARROW + NOTCH = DIRECTION OF ROTATION

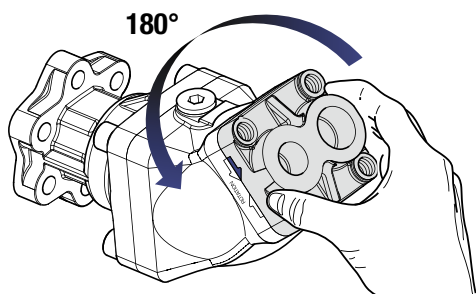

ATTENZIONE:
durante l'operazione il fondello non deve mai distaccarsi dal corpo pompa per più di 2 mm.

WARNING:
during this operation the distributor body must not move away from the pump body more than 2 mm.

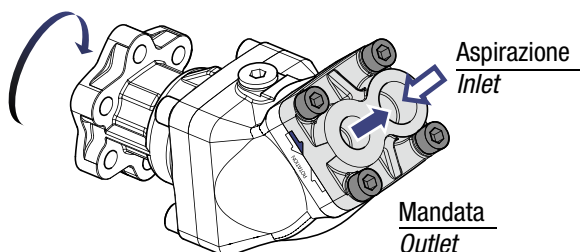

POMPA ROTAZIONE SINISTRA
(P.T.O. ROTAZIONE DESTRA)

ANTICLOCKWISE ROTATING PUMP
(CLOCKWISE ROTATING P.T.O.)